



# QuadUniversal

**Additional Rotary Axis for High Precision Co-Ordinate Measurement Machines. All Quadrant products are ISO 10360 part 3 compliant.**

Precision rotary axes specifically developed to increase the flexibility, productivity and efficiency of your CMM.

For automotive applications where ultimate precision may not be required.

#### Measurement Capacity:

- Size Ø600mm
- Overall height 130mm
- Load capacities up to 100kgs
- Zero backlash drive
- Angular accuracy 6.5 arc seconds
- Angular repeatability 0.5 arc seconds

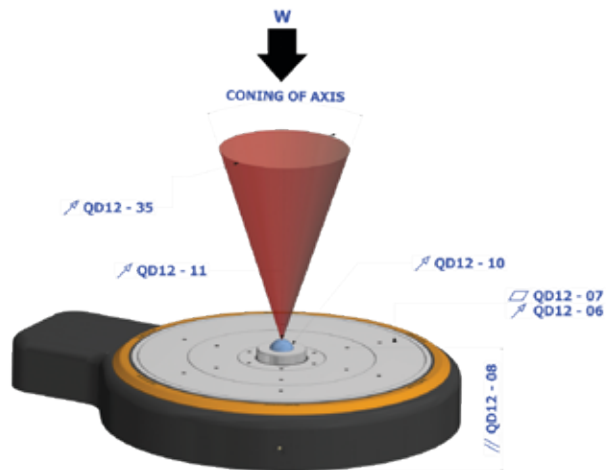
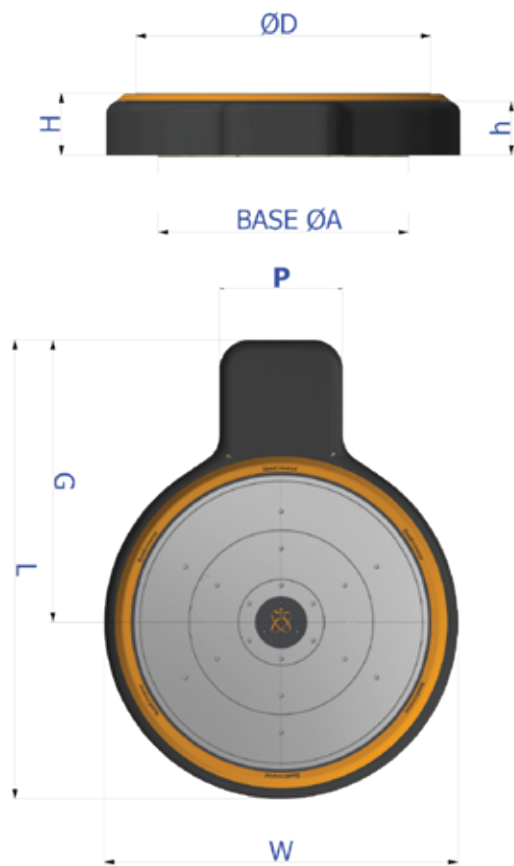

## QuadUniversal

Technical Data	QD	Units	QuadUniversal 600
Load Capacity		kgs	100
Maximum Tilt Moment		Nm	30
Coning of Table Axis	12-35	Arc seconds	+/-1
Maximum Acceleration @ Min Inertia		Rad/s <sup>2</sup>	10
Maximum Acceleration @ Max Inertia		Rad/s <sup>2</sup>	2
Maximum Polar Inertia		kgm <sup>2</sup>	7.6
Angular Positioning Accuracy		Arc seconds	6.5
Angular Resolution (Options Available)	12-56	Arc seconds	0.18
Angular Repeatability	12-57	Arc seconds	0.5
Drive Ratio			600:1
Maximum rpm		rpm	5
Rotation Error of Table Top	12-06	mm	0.010
Flatness of Table Top	12-07		0.010
Parallelism of Table Top To Base	12-08		0.015
Radial Runout of Table Axis	12-10		0.001
Axial Runout of Table Axis	12-11		0.001

	Dimensions								Weight
	ØA	ØD	G	H	h	L	P	W	
Units	MM								kgs
QuadUniversal 600	480	600	575	130	113	935	250	720	95
Flexible Tooling Interface	HSK, Lang, Schunk, Gewefa (other options available on request)								