

# LabStandardDUO

## High Precision Angular Positioning, Calibration and Geometry Inspection

Ultra precise rotary tables intended for fine inspection, metrology and test applications.

2 axis design for rotary tilting applications with self-locking worm gearing and a high accuracy angular encoder ensures sensitivity and fine positioning for metrology and precision testing.

### Measurement Capacity:

- 360° Rotary and -10° to +180° tilting axis
- Sizes Ø250mm, Ø300mm, and Ø400mm
- Overall height 225mm (axis vertical)
- Centreline height 342mm (axis horizontal)
- Load capacities up to 175kgs
- Load moment up to 300Nm
- Powerful pneumatic clamps (optional)
- Angular accuracy 2 arc seconds
- Angular repeatability 0.5 arc seconds

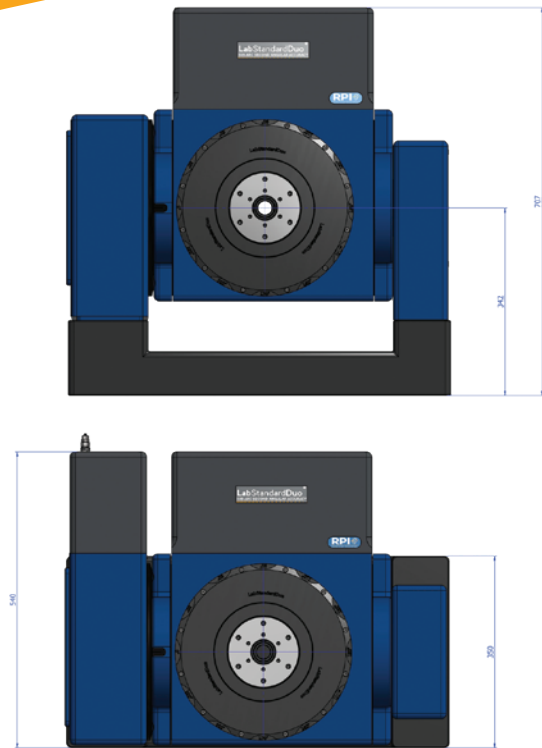
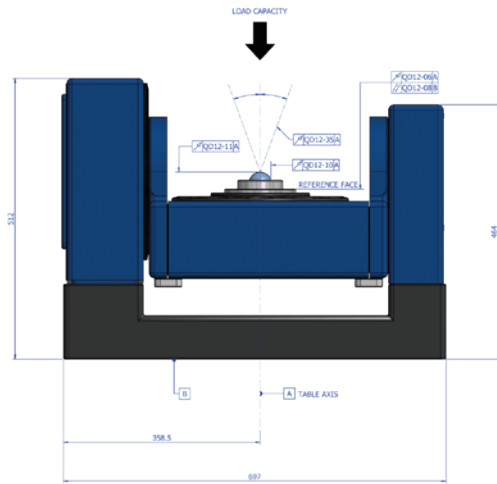

## LabStandardDUO

Technical Data	QD	Unit	LabStandardDUO10	LabStandardDUO5	LabStandardDUO2	LabStandardDUO+
Centre Line Height		mm			342	
Load Capacity		kgs			175	
Load Moment		Nm			300	
Tilting Capacity		Degrees			-10 / 180	
Maximum Polar Inertia (Rotary)		kgm <sup>2</sup>			40	
Maximum rpm (Rotary)		rpm			4	
Maximum rpm (Tilt)		rpm			1	
Spindle Rotation Error	12-06	mm			0.005	
Parallelism	12-08	mm			0.006	
Angular Positioning Accuracy (Rotary)	12-09	Arc seconds	10	5	2	1
Angular Repeatability (Rotary)			+/-0.5		+/-0.2	
Angular Positioning Accuracy (Tilt)	12-09		10	5	3	
Angular Repeatability (Tilt)			+/-0.5		+/-0.2	
Resolution	12-56		0.1			
Clamp Shift (If Fitted as option both axis)		<2				
Radial Runout of Table Axis	12-10	mm			0.0005	
Axial Runout of Table Axis	12-11	mm			0.0003	
Coning of Table Axis	12-35	Arc seconds	+/-1		+/-0.5	
Concentricity of Centre Bore	12-36	mm	0.005		0.0025	
Table Weight (Without Table Top option)		kgs	280			
Table Top Options		mm	Ø250, 300, 400			
Flexible Tooling Interface			HSK, Lang, Schunk, Gewefa (other options available on request)			